

9.2

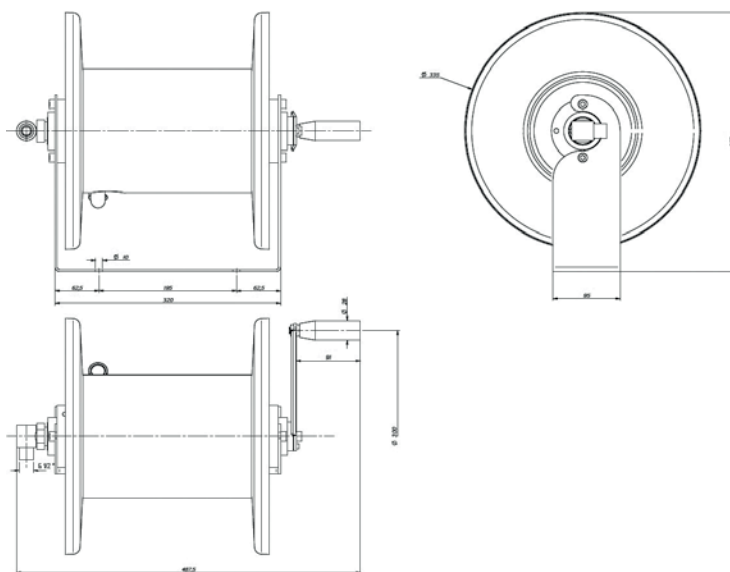

Arrotolatore Inox Manuale A.P. equipaggiabile con tubo R/1 da 1/2" per impianti sino a 100 Bar o con R/2 da 3/8" per impianti sino a 200 Bar o FOODJET da 1/2" per impianti a bassa e media pressione sino a 50 Bar.



ARROTOLATORE MANUALE

CODICE	MATERIALE ARROTOLAT.	Ø (mm)	UTILIZZO IN PRESSIONE	TUBO	LUNGH. TUBO (mt)	SEZIONE TUBO	PRESSIONE MAX TUBO (bar)	PESO (Kg)	DIMENSIONI (LxHxP) mm
10.0447.00	Inox	330	Bassa - Media Alta	-	-	-	-	9	500x330x370
10.4155.00	Inox	330	Bassa	5/8"	15	5/8" (Ø16x26)	15	20	500x330x370
10.4153.00	Inox	330	Media	FOOD JET	20	1/2"	80	25	500x330x370
10.4154.00	Inox	330	Media	R/1	20	1/2"	100	25	500x330x370
10.1495.00	Inox	330	Alta	R/2	20	3/8"	200	18	500x330x370

DIMENSIONI (mm)

A	B	C	D	E	F	G	H	I	M	N	O	P	Q	R	S	T
2X10	70	30	100	150	250	290	330	150	1/2"	200	320	95	195	500	370	62,5